

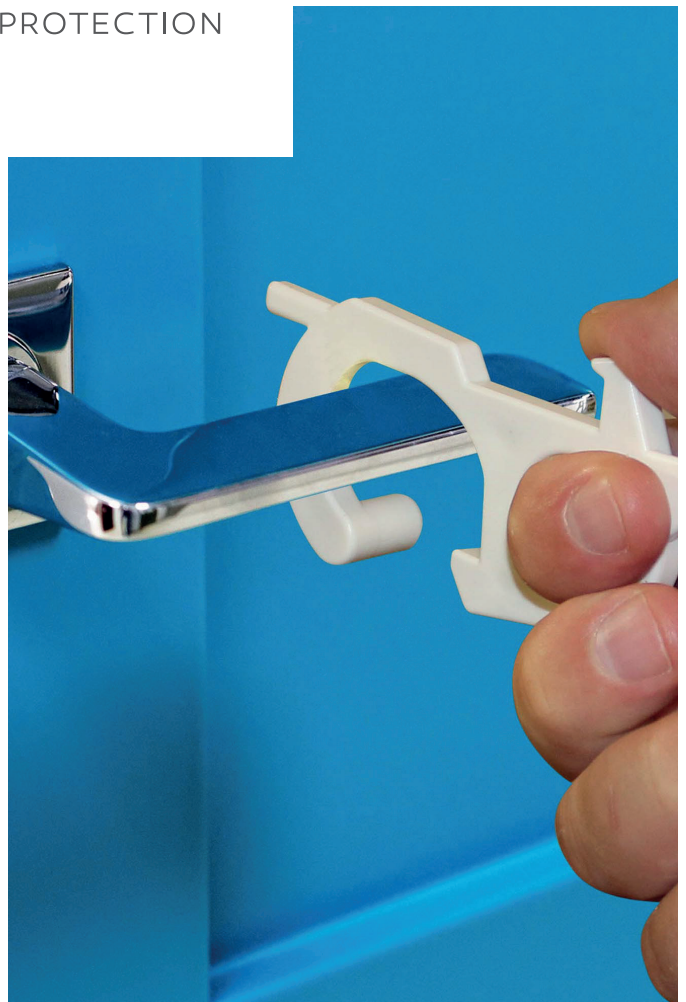

MATERIAL DE PROTECCIÓN
PROTECTIVE MATERIAL
MATÉRIEL DE PROTECTION

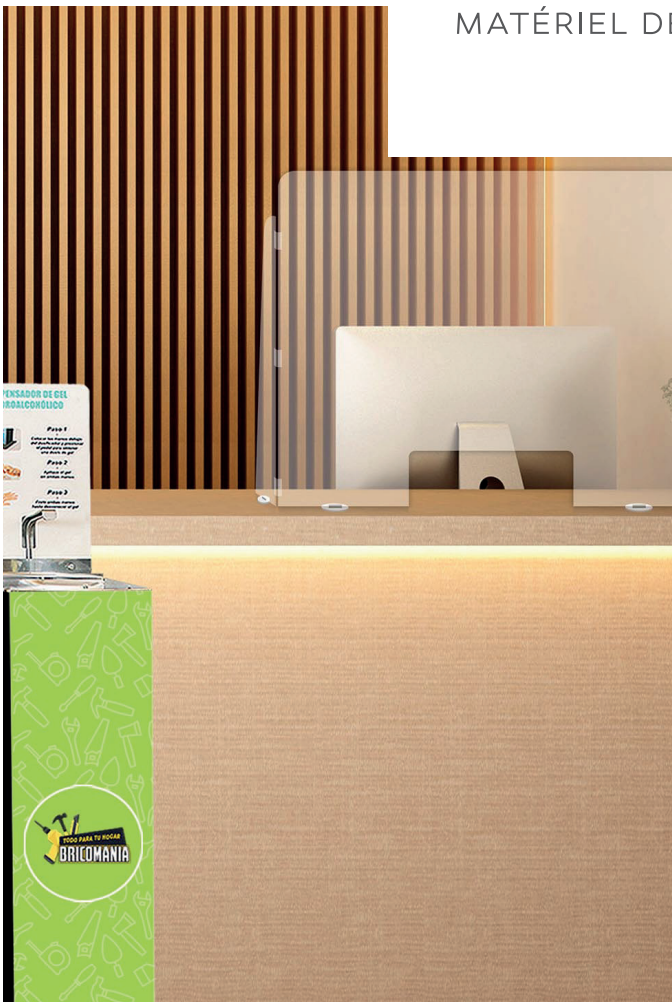

04

VISERAS
FACE SHIELDS
VISIÈRES



10

MASCARILLAS
MASKS
MASQUES



14

LANYARD PORTAMASCARILLAS
MASK HOLDER LANYARD
LANYARD PORTE-MASQUE



15

SUJETA MASCARILLA
MASK HOLDER
PROTECTEUR D'OREILLÉ

16

PORTAMASCARILLAS
MASK HOLDER
PORTE MASQUE



20

TORRE HIGIÉNICA
GEL TOWER
STATION HYGIÈNIQUE

21

MAMPARAS PROTECCIÓN
PROTECTION SCREENS
ÉCRANS DE PROTECTION

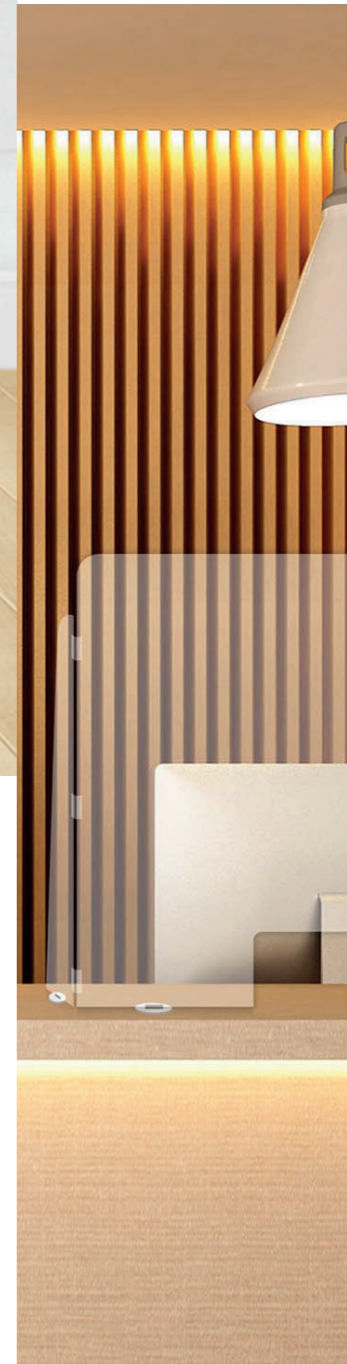

22

DISPOSITIVO MULTIFUNCIONAL
MULTIFUNCTIONAL DEVICE
DISPOSITIF MULTIFONCTIONNEL



23

ARENA PLACE
BEACH DELIMITER
DELIMITER DE PLAGE



VISERAS PERSONALIZABLES.

PERSONALIZED FACE SCREEN. VISIÈRE DE PROTECTION PERSONNALISÉE.



Visera personalizable antivaho (PVO05/006) Personalized anti-fog face screen Visière de protection personnalisée anti-buée

Visera de protección facial frente a enfermedades infecciosas, evita salpicaduras y contacto directo con agentes biológicos patógenos. The face screen protects against direct contact with drip-distributed biological agents and pathogens. Visières por protège contre le contact direct avec les agents biologiques distribués au goutte et pathogènes.

Colocación. Placement. Emplacement.
Ajuste mediante elástico adaptable de 20mm.
Adjustable rubber band 20mm.
Bande élastique 20mm.

Material. Material. Matériel.
PETG antivaho con espuma foam interior.
Anti-fog face screen PETG with foam band interior.
PETG anti-buée avec de la mousse intérieur.

Personalización. Personalization. Personnalisation.
PVO05 personalizable. PVO06 diseño genérico.
PVO05 customizable. PVO06 standard design.
PVO05 personnalisation. PVO06 desing standard.

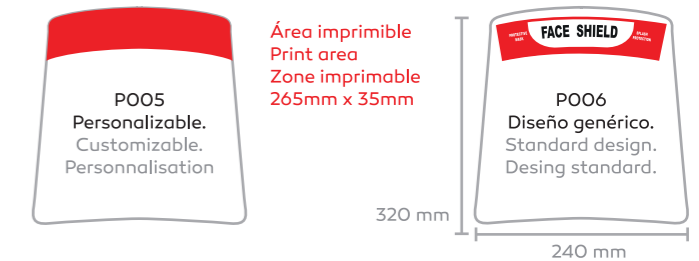
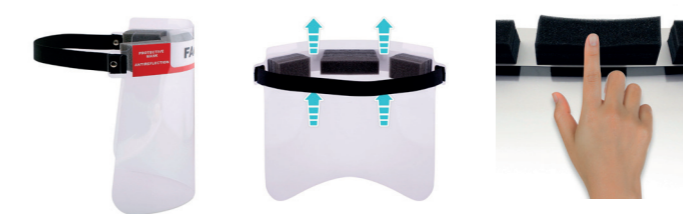

Visera personalizable básica (PVO03/004) Personalized Basic face screen Visières personnalisables basic

Visera de protección facial frente a enfermedades infecciosas, evita salpicaduras y contacto directo con agentes biológicos patógenos. The face screen protects against direct contact with drip-distributed biological agents and pathogens. Visières por protège contre le contact direct avec les agents biologiques distribués au goutte et pathogènes.

Colocación. Placement. Emplacement.
Ajuste mediante elástico adaptable de 20mm.
Adjustable rubber band 20mm.
Bande élastique 20mm.

Material. Material. Matériel.
PETG con espuma foam interior. (sin antivaho)
PETG with foam band interior. (no anti-fog)
PETG avec de la mousse intérieur. (Pas d'anti-buée)

Personalización. Personalization. Personnalisation.
PVO03 personalizable. PVO04 diseño genérico.
PVO03 customizable. PVO04 standard design.
PVO03 personnalisation. PVO04 desing standard.

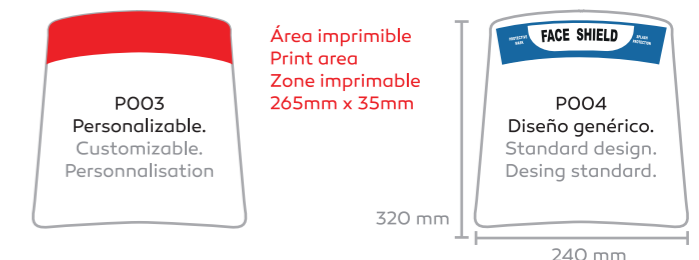



Visera especial EPI (MASCPRO)
PPE Special Face Screen
Visière spéciale EPI

Visera de protección facial frente a enfermedades infecciosas, evita salpicaduras y contacto directo con agentes biológicos patógenos. Certificado especial material de protección individual EPI, especial sanitarios, farmacéuticos, dentistas, etc.
 The face screen protects against direct contact with drip-distributed biological agents and pathogens. Special certificate for personal protective equipment PPE, especially for health professionals, pharmacists, dentists, etc.
 Visières por protège contre le contact direct avec les agents biologiques distribués au goutte-à-goutte et pathogènes. Certificat spécial pour le matériel de protection individuelle, le EPI, les appareils sanitaires spéciaux, les produits pharmaceutiques, les dentistes, etc.

 **Colocación.** Placement. Emplacement.
Fijación trasera PU inyectado ajustable.
 Fixing PU adjustable injection.
 Fixation arrière en PU injecté réglable.

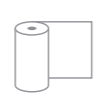
 **Material.** Material. Matériel.
PETG antivaho.
 Anti-fog face screen PETG.
 PETG anti-buée .

MASCPRO
 Opcion de personalización: consultar.
 Customization option.: consult.
 Option de personnalisation.: consulter.

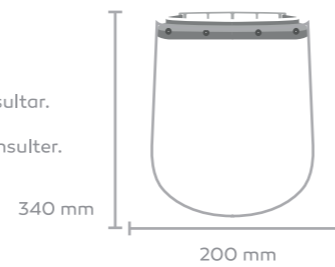

Visera semi-casco (PVO300CBFT)
Semi-helmet Face Screen
Visière Semi-Casque

Visera de protección facial frente a enfermedades infecciosas, evita salpicaduras y contacto directo con agentes biológicos patógenos.
 The face screen protects against direct contact with drip-distributed biological agents and pathogens.
 Visières por protège contre le contact direct avec les agents biologiques distribués au goutte-à-goutte et pathogènes.

 **Colocación.** Placement. Emplacement.
Fijación trasera PU inyectado ajustable.
 Fixing PU adjustable injection.
 Fixation arrière en PU injecté réglable.

 **Material.** Material. Matériel.
PETG antivaho.
 Anti-fog face screen PETG.
 PETG anti-buée .

MASCPRO
 Opcion de personalización: consultar.
 Customization option.: consult.
 Option de personnalisation.: consulter.

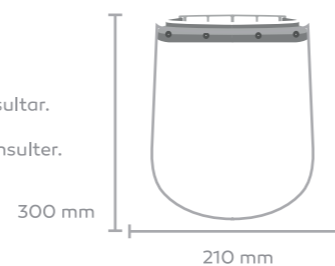

Visera automontable personalizada (PVO09)
Personalized self-assemble face screen
Visière auto-assemblage

Visera de protección facial frente a enfermedades infecciosas, evita salpicaduras y contacto directo con agentes biológicos patógenos.
 The face screen protects against direct contact with drip-distributed biological agents and pathogens.
 Visières por protège contre le contact direct avec les agents biologiques distribués au goutte et pathogènes.

 **Colocación.** Placement. Emplacement.
Ajuste mediante sistema automontable.
 Self-mounting.
 Réglage facile par système d'auto-montage.

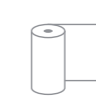
 **Material.** Material. Matériel.
PETG de 300 micras de grosor.
 PETG 300 micron.
 PETG de 300 microns.

 **Personalización.** Personalization. Personnalisation.
PVO09 personalizable. PVO09 diseño genérico.
 PVO09 customizable. PVO09 standard design.
 PVO09 personnalisation. PVO09 desing standard.

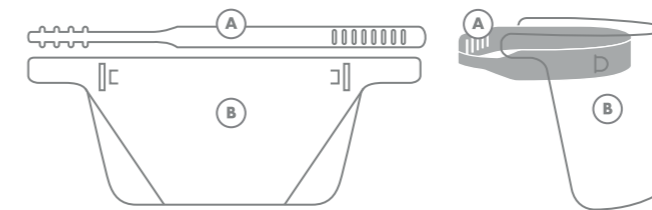
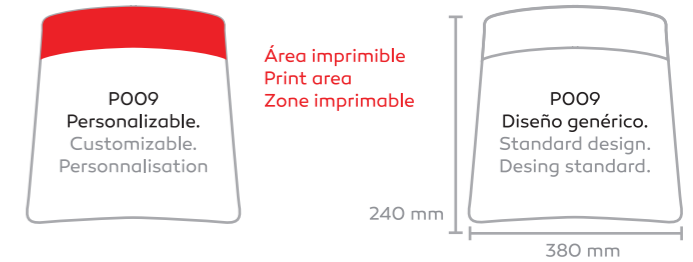

Visera automontable (PVO01/002)
Face screen self-assemble
Visière auto-assemblage

Visera de protección facial frente a enfermedades infecciosas, evita salpicaduras y contacto directo con agentes biológicos patógenos.
 The face screen protects against direct contact with drip-distributed biological agents and pathogens.
 Visières por protège contre le contact direct avec les agents biologiques distribués au goutte et pathogènes.

 **Colocación.** Placement. Emplacement.
Ajuste mediante sistema automontable.
 Self-mounting.
 Réglage facile par système d'auto-montage.

 **Material.** Material. Matériel.
PETG de 500 micras de grosor.
 PETG 500 micron.
 PETG de 500 microns.

 **Formatos.** Formats. Formats.
PVO01: 695mm x 208mm PVO02: 695mm x 237mm.
 PVO01: 695mm x 208mm PVO02: 695mm x 237 mm.
 PVO01: 695mm x 208mm PVO02: 695mm x 237 mm.

No personalizable. Not customizable. Non personnalisable.

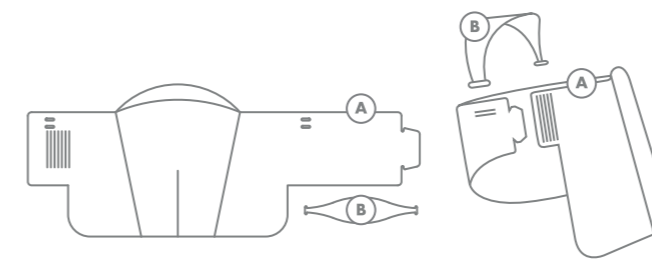
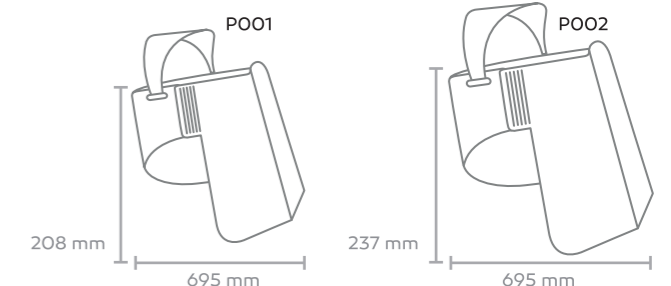



Visera infantil antivaho (PVO08)
 Personalized anti-fog face screen
 Visière de protection personnalisée anti-buée

Visera de protección facial frente a enfermedades infecciosas, evita salpicaduras y contacto directo con agentes biológicos patógenos. The face screen protects against direct contact with drip-distributed biological agents and pathogens. Visières por protège contre le contact direct avec les agents biologiques distribués au goutte et pathogènes.

- Colocación. Placement. Emplacement.**
 Ajuste mediante elástico adaptable de 16mm.
 Adjustable rubber band 16mm.
 Bande élastique 16mm.
- Material. Material. Matériel.**
 PETG antivaho con espuma foam interior.
 Anti-fog face screen PETG with foam band interior.
 PETG anti-buée avec de la mousse intérieur.
- Personalización. Personalization. Personnalisation.**
 Diseño genérico unisex con 2 adhesivos (niño-niña)
 Generic unisex design with 2 stickers (boy-girl)
 Design générique unisexe avec 2 autocollants (garçon-fille)

Formato especial infantil apto a partir de 4 años.
 Special format for children, suitable from 4 years old.
 Format spécial pour les enfants, convient à partir de 4 ans.

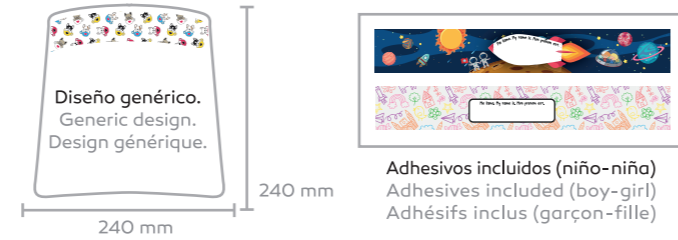
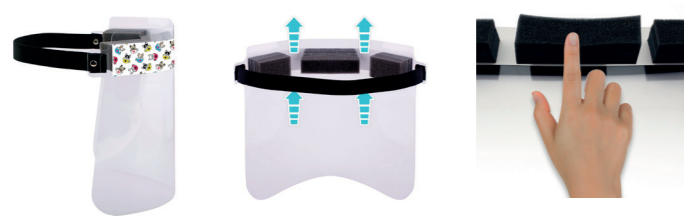

Visera infantil básica (PVO07)
 Basic children's face screen
 Visière de protection pour enfants basic

Visera de protección facial frente a enfermedades infecciosas, evita salpicaduras y contacto directo con agentes biológicos patógenos. The face screen protects against direct contact with drip-distributed biological agents and pathogens. Visières por protège contre le contact direct avec les agents biologiques distribués au goutte et pathogènes.

- Colocación. Placement. Emplacement.**
 Ajuste mediante elástico adaptable de 16mm.
 Adjustable rubber band 16mm.
 Bande élastique 16mm.
- Material. Material. Matériel.**
 PETG con espuma foam interior. (sin antivaho)
 PETG with foam band interior. (no anti-fog)
 PETG avec de la mousse intérieur. (Pas d'anti-buée)
- Personalización. Personalization. Personnalisation.**
 Diseño genérico unisex con 2 adhesivos (niño-niña)
 Generic unisex design with 2 stickers (boy-girl)
 Design générique unisexe avec 2 autocollants (garçon-fille)

Formato especial infantil apto a partir de 4 años.
 Special format for children, suitable from 4 years old.
 Format spécial pour les enfants, convient à partir de 4 ans.

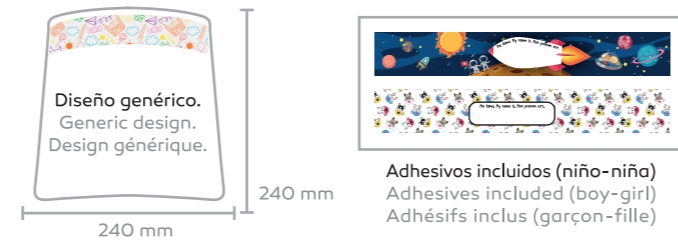

Visera automontable personalizada infantil (PVO10)
 Personalized children's face screen self-assembly
 Visière auto-assemblage pour enfants

Visera de protección facial frente a enfermedades infecciosas, evita salpicaduras y contacto directo con agentes biológicos patógenos. The face screen protects against direct contact with drip-distributed biological agents and pathogens. Visières por protège contre le contact direct avec les agents biologiques distribués au goutte et pathogènes.

- Colocación. Placement. Emplacement.**
 Ajuste mediante sistema automontable.
 Self-mounting.
 Réglage facile par système d'auto-montage.
- Material. Material. Matériel.**
 PETG de 300 micras de grosor.
 PETG 300 micron.
 PETG de 300 microns.
- Personalización. Personalization. Personnalisation.**
 Personalizable o neutro sin impresión.
 Personalized design or neutral no printing.
 Design personnalisé, ou neutre sans impression.

Formato especial infantil apto a partir de 4 años.
 Special format for children, suitable from 4 years old.
 Format spécial pour les enfants, convient à partir de 4 ans.

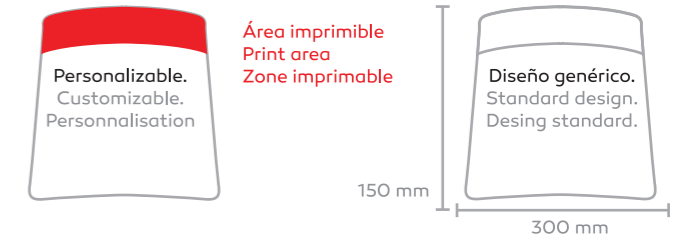
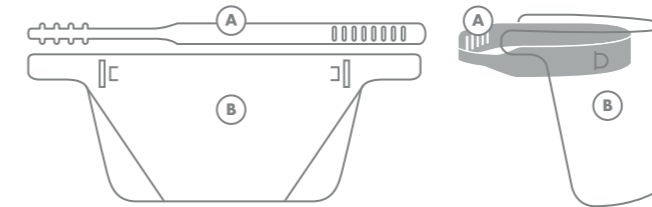

Montura gafa con pantalla (PVO11)
 Glasses frame with screen
 Monture de lunettes avec écran

Visera de protección facial frente a enfermedades infecciosas, evita salpicaduras y contacto directo con agentes biológicos patógenos. The face screen protects against direct contact with drip-distributed biological agents and pathogens. Visières por protège contre le contact direct avec les agents biologiques distribués au goutte et pathogènes.

- Colocación. Placement. Emplacement.**
 Ajuste mediante gafa.
 Fit through glasses.
 Monter à travers des lunettes.
- Material. Material. Matériel.**
 PETG de 300 micras de grosor.
 PETG 300 micron.
 PETG de 300 microns.
- Personalización. Personalization. Personnalisation.**
 No personalizable.
 Not customizable.
 Non personnalisable.

1. Retira la lámina protectora de la pantalla 2. Coloca la pantalla en la gafa.
 1. Remove the protective foil from the screen 2. Place the screen on the glasses.
 1. Retirez la feuille de protection de l'écran 2. Placez l'écran sur les Lunettes.

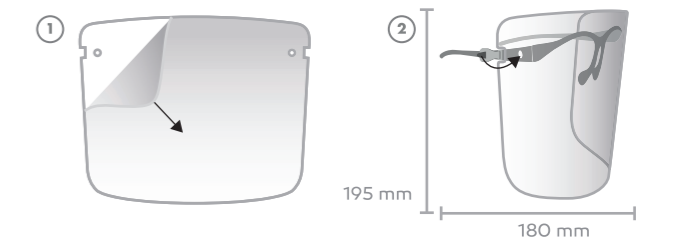
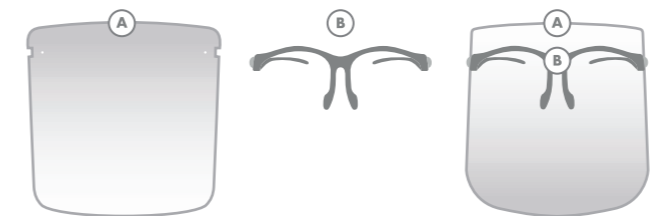

COBERTOR FACIAL COMUNITARIO REUTILIZABLE.
REUSABLE COMMUNITY FACIAL COVER
COUVERTURE FACIALE COMMUNAUTAIRE RÉUTILISABLE



CERTIFICADO EUROFINIS
20 LAVADOS

EUROFINIS CERTIFIED
20 WASHES

CERTIFICAT EUROFINIS
20 LAVAGES

RESPIRABILIDAD
24,6%

BREATHABILITY
24,6%

RESPIRABILITE
24,6%

HOMOLOGADO POR. APPROVED BY.
APPROUVÉ POUR.

euofins

EFICACIA DE FILTRACION BACTERIANA
BFE 97,9%

FILTRATION EFFICIENCY BACTERIAL
BFE 97,9%

EFFICACITÉ DE FILTRATION BACTÉRIENNE
BFE 97,9%

Global Recycled Standard
50% TEJIDO RECICLADO

ANTIBACTERIAS
ANTIBACTERIAS

LAVABLE A MAQUINA
MACHINE WASHABLE

ELÁSTICO ADAPTABLE
ADJUSTABLE BAND

EMBOLSADO
POLY BAG

PERSONALIZACIÓN
CUSTOMIZATION

WATER PROOF
WATER PROOF

CERTIFIED
UNE 0065/2020

CERTIFIED
UNE-CWA 17553-2020

MASCARILLAS HIGIÉNICAS REUTILIZABLES.

PERSONALIZED REUSABLE MASK. MASQUE RÉUTILISABLE PERSONNALISÉ.



Mascarilla personalizada reutilizable (MCO04)
Personalized reusable mask
Masque réutilisable personnalisé

Mascarilla higiénica reutilizable con elásticos de fijación y pinza adaptable en la zona de la nariz para un mejor ajuste, protege las vías respiratorias de la inhalación de partículas y agentes contaminantes.

Reusable hygienic mask with fixing elastics and an adaptable clip in the nose area for a better fit, protects the airways from inhaling particles and contaminating agents.

Masque hygiénique réutilisable avec élastiques de fixation et clip adaptable dans la zone du nez pour un meilleur ajustement, protège les voies respiratoires de l'inhalation de particules et d'agents contaminants.



Colocación. Placement. Emplacement.
 Elásticos de fijación y pinza adaptable en la nariz.
 Fixing elastics and an adaptable clip in the nose area.
 Élastiques de fixation et clip adaptable dans la zone du nez.



Personalización. Personalization. Personnalisation.
 Impresión en toda la superficie o sin impresión alguna.
 Printing on the entire surface or without any printing.
 Impression sur toute la surface ou sans aucune impression.

Nuestras mascarillas están certificadas y cumplen con la norma:
 Our masks are certified and comply with the product regulations:
 Nos masques sont certifiées et conformes aux normes:
EN 14683:2019 + AC:2019 BAJO UNE 0065/2020.



2 tamaños, adulto e infantil.
 2 sizes, adult and child.
 2 tailles, adulte et enfant.
 Área imprimible
 Print area
 Zone imprimable

MATERIAL (RESPIMASK):

Triple capa de poliéster. triple layer of polyester. triple couche de polyester.

1.Capa: tejido hidrofugo y oleofugo antibacterias y antifúngico de sal de plata finamente dispersado.
 1.Layer: With water-repellent and oleofugo finish antibacterial and antifungal of finely dispersed silver salt.

1.Couche: avec finition hydrofuge et oléofugo antibactérien et antifongique de sel d'argent finement dispersé (ION ARGENT).

2. Capa: filtro espuma poliéster.
 2. Layer: polyester foam filter.
 2. Cuche: filtre en mousse polyester

3. Capa: tejido water 50 gr.
 3. Layer: water fabric 50 gr.
 3. Couche: tissu d'eau de 3ème couche 50 gr.

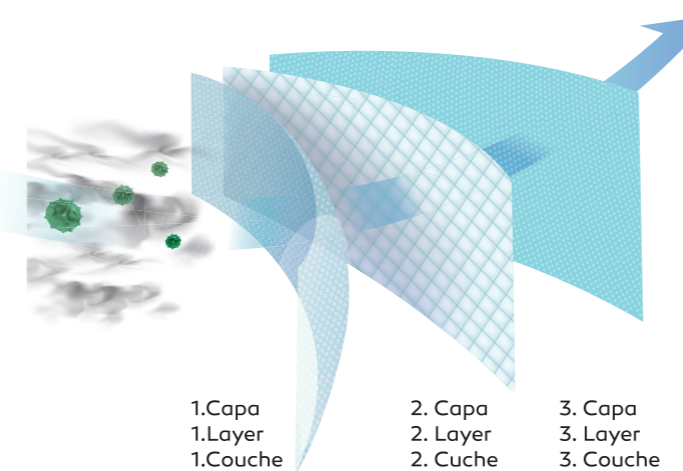

euofins

ENSAYO EUROFINIS. EUROFINIS TEST. TEST EUROFINIS.	AR-20-YL-008623-01-EN AR-20-YL-008624-01-EN
EFICACIA DE FILTRACION BACTERIANA (BFE) EFFICIENCY OF BACTERIAL FILTRATION (BFE) EFFICACITÉ DE LA FILTRATION BACTÉRIENNE (BFE)	97,9%
(BFE) DESPUES DE 20 LAVADOS (BFE) AFTER 20 WASHES. (BFE) APRÈS 20 LAVAGES.	95,7%

PRESION DIFERENCIAL. DIFFERENTIAL PRESSURE. PRESSION DIFFÉRENTIELLE.	24,6 +/- 1,4 Pa/cm2
PRESION DIFERENCIAL DESPUES DE 20 LAVADOS. DIFFERENTIAL PRESSURE AFTER 20 WASHES. PRESSION DIFFÉRENTIELLE APRÈS 20 LAVAGES.	24,5 +/- 1,1 Pa/cm2
LAVADOS GARANTIZADOS. GUARANTEED WASHES. LAVAGES GARANTIS	20 (40° a 60°)



**COBERTOR FACIAL COMUNITARIO REUTILIZABLE.
REUSABLE COMMUNITY FACIAL COVER
COUVERTURE FACIALE COMMUNAUTAIRE RÉUTILISABLE**

**PINZA AJUSTABLE PARA ZONA NARIZ
ADAPTABLE CLIP IN THE NOSE AREA
CLIP ADAPTABLE DANS LA ZONE DU NEZ**

**ELÁSTICOS LATERALES ADAPTABLES
ADAPTABLE ELASTICS
ÉLASTIQUES LATÉRALES ADAPTABLES**

MADE IN SPAIN

**HOMOLOGADO POR. APPROVED BY
APPROUVÉ POUR.**

euofins

EFICACIA DE FILTRACIÓN BACTERIANA (BFE) 97,9%

FILTRATION EFFICIENCY (BFE) 97,9%

EFFICACITÉ DE FILTRATION BACTÉRIENNE (BFE) 97,9%

**Global Recycled Standard
50% TEJIDO RECICLADO**

ANTIBACTERIAS

**LAVABLE A MAQUINA
MACHINE WASHABLE**

**ELÁSTICO ADAPTABLE
ADJUSTABLE BAND**

**EMBOLSADO
POLY BAG**

**PERSONALIZACIÓN
CUSTOMIZATION**

WATER PROOF

RESPIRABILIDAD 24,6%

BREATHABILITY 24,6%

RESPIRABILITE 24,6%

RESPIRABILIDAD 24,6%

BREATHABILITY 24,6%

RESPIRABILITE 24,6%

CERTIFICADO EUROFINES 20 LAVADOS

EUROFINES CERTIFIED 20 WASHES

CERTIFICAT EUROFINES 20 LAVAGES

UNE 0065/2020 CERTIFIED

UNE-CWA 17553-2020 CERTIFIED



Mascarilla personalizada reutilizable premium (MCO06)
Personalized hygienic reusable premium mask
Masque premium hygiénique personnalisable réutilisable

Mascarilla higiénica reutilizable alta calidad homologada y certificada con elásticos ajustables de fijación y pinza adaptable en la zona de la nariz para un mejor ajuste, protege las vías respiratorias de la inhalación de partículas y agentes contaminantes. Homologated and certified reusable hygienic high quality mask with adjustable fixation elastics and adaptable clip in the nose area for a better fit, protects the respiratory tract from the inhalation of particles and pollutants. Masque hygiénique réutilisable haute qualité homologué et certifié avec élastiques de fixation réglables et clip adaptable dans la zone du nez pour un meilleur ajustement, protège les voies respiratoires de l'inhalation de particules et de polluants.



Colocación. Placement. Emplacement.
Elásticos de fijación y pinza adaptable en la nariz.
Fixing elastics and an adaptable clip in the nose area.
Élastiques de fixation et clip adaptable dans la zone du nez.



Personalización. Personalization. Personnalisation.
Impresión en toda la superficie o sin impresión alguna.
Printing on the entire surface or without any printing.
Impression sur toute la surface ou sans aucune impression.

Nuestras mascarillas están certificadas y cumplen con la norma:
Our masks are certified and comply with the product regulations:
Nos masques sont certifiées et conformes aux normes:
EN 14683:2019 + AC:2019 BAJO UNE 0065/2020.

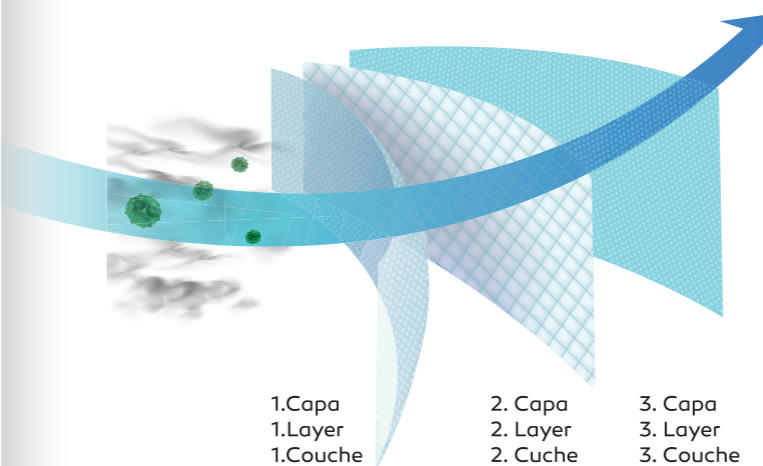

MATERIAL (PRONOMASK):

Triple capa de poliéster. triple layer of polyester. triple couche de polyester.
1.Capa: tejido de poliéster lycra.
1.Layer: polyester lycra fabric.
1.Couche: tissu polyester lycra.
2. Capa: tejido de foam sanitario.
2. Layer: sanitary foam fabric.
2. Couche: tissu en mousse hygiénique
3. Capa: poliéster de iones de plata.
3. Layer: silver ion polyester.
3. Couche: polyester aux ions d'argent.

euofins



ENSAYO EUROFINES. EUROFINES TEST. TEST EUROFINES.	AR-20-YL-008623-01-EN AR-20-YL-008624-01-EN	PRESIÓN DIFERENCIAL. DIFFERENTIAL PRESSURE. PRESSION DIFFÉRENTIELLE.	24,6 +/- 1,4 Pa/cm2
EFICACIA DE FILTRACIÓN BACTERIANA (BFE) EFFICIENCY OF BACTERIAL FILTRATION (BFE) EFFICACITÉ DE LA FILTRATION BACTÉRIENNE (BFE)	97,9%	PRESIÓN DIFERENCIAL DESPUES DE 20 LAVADOS. DIFFERENTIAL PRESSURE AFTER 20 WASHES. PRESSION DIFFÉRENTIELLE APRÈS 20 LAVAGES.	24,5 +/- 1,1 Pa/cm2
(BFE) DESPUÉS DE 20 LAVADOS (BFE) AFTER 20 WASHES. (BFE) APRÈS 20 LAVAGES.	95,7%	LAVADOS GARANTIZADOS. GUARANTEED WASHES. LAVAGES GARANTIS	20 (40° a 60°)



LANYARD Y SUJETA MASCARILLA.

LANYARD AND MASK HOLDER. LANYARD PORTE MASQUE ET PROTECTEUR D' OUREILLE.



Lanyard portamascarillas (PVO12) Mask holder lanyard Lanyard porte-masque

Lanyard para sujetar la mascarilla y evitar dejarla en superficies.
Lanyard to hold the mask and avoid leaving it on surfaces.
Lanyard pour maintenir le masque et éviter de le laisser sur les surfaces.



Colocación. Placement. Emplacement.
Lanyard con ganchos.
Lanyard with hooks.
Lanyard avec crochets.



Material. Material. Matériel.
Textil poliéster.
Polyester textile.
Textile en polyester.



Personalización. Personalization. Personnalisation.
Varios colores base y posibilidad de personalización.
Various base colors and possibility of customization.
Différentes couleurs de base et possibilité de personnalisation.

Colores base
Base colors
Couleurs de base



Personalizadas
Customized
Personnalisées



Sujeta Mascarilla Personalizable (MCO02) Personalized Mask Holder Protecteur d'oreillé pour masques

Sujeta y ajusta las mascarillas por la parte trasera de la cabeza para evitar el roce, marcas e irritaciones producidas por las gomas de las mascarillas en las orejas.
Holds and adjusts the masks from the back of the head to avoid rubbing, marks and irritations produced by the gums of the masks on the ears.
Fixes et ajustez les masques à l'arrière de la tête pour éviter les frottements, marques, etc.



Material. Material. Matériel.
Polipropileno PP.
Polypropylene PP.
Polypropylène PP.



Personalización. Personalization. Personnalisation.
1. Piezas individuales sin ninguna impresión (neutro).
2. Piezas individuales impresas (personalizadas).
3. Planchas con las piezas troqueladas para poder imprimir.
1. Individual pieces without any printing (neutral).
2. Printed individual pieces (customized).
3. Plates with die cut pieces to be able to print.
1. Pièce neutre sans personnalisation.
2. Pièces individuelles imprimées (personnalisées).
3. Avec des plaques découpées pour marquage.



Neutro
Neutral
Neutre



Personalizadas
Customized
Personnalisées



Planchas troqueladas
Die-cut plates
Plaques découpées



PORTAMASCARILLAS.

MASK HOLDER. PORTE MASQUE.



Portamascarillas de bolsillo (PVO13) Pocket Mask Holder Support de masque de poche

Portamascarillas de bolsillo personalizable ideal para el transporte y protección de tu mascarilla, llévalo colgado en el lanyard o guárdalo en el bolsillo, mochila, bolso, etc. Material resistente, automontable, reutilizable y de fácil limpieza.

Customizable pocket mask holder ideal for transporting and protecting your mask, carry it hanging on the lanyard or keep it in your pocket, backpack, bag, etc. Resistant material, self-assembling, reusable and easy to clean.

Support de masque de poche personnalisable idéal pour transporter et protéger votre masque, utiliser avec lanyard ou le garder dans votre poche, sac à dos, sac, etc. Matériau résistant, auto-assemblant, réutilisable et facile à nettoyer.



Material. Material. Materiel.
Polipropileno translúcido o opaco.
Translucent or opaque polypropylene.
Polypropylène translucide ou opaque.



Personalización. Personalization. Personnalisation.
Personalizable a todo color, 1 color o neutro sin impresión.
Customizable in full color, 1 color or neutral without printing.
Personnalisable en quadrichromie, 1 couleur ou neutre sans impression.



Área imprimible a todo color
Full color printable area
Zone imprimible en couleur

FORMATO / FORMAT / FORMAT

- (A) Sin lanyard. Without lanyard. Sans lanière.
- (B) Con lanyard. With lanyard. Avec lanière.

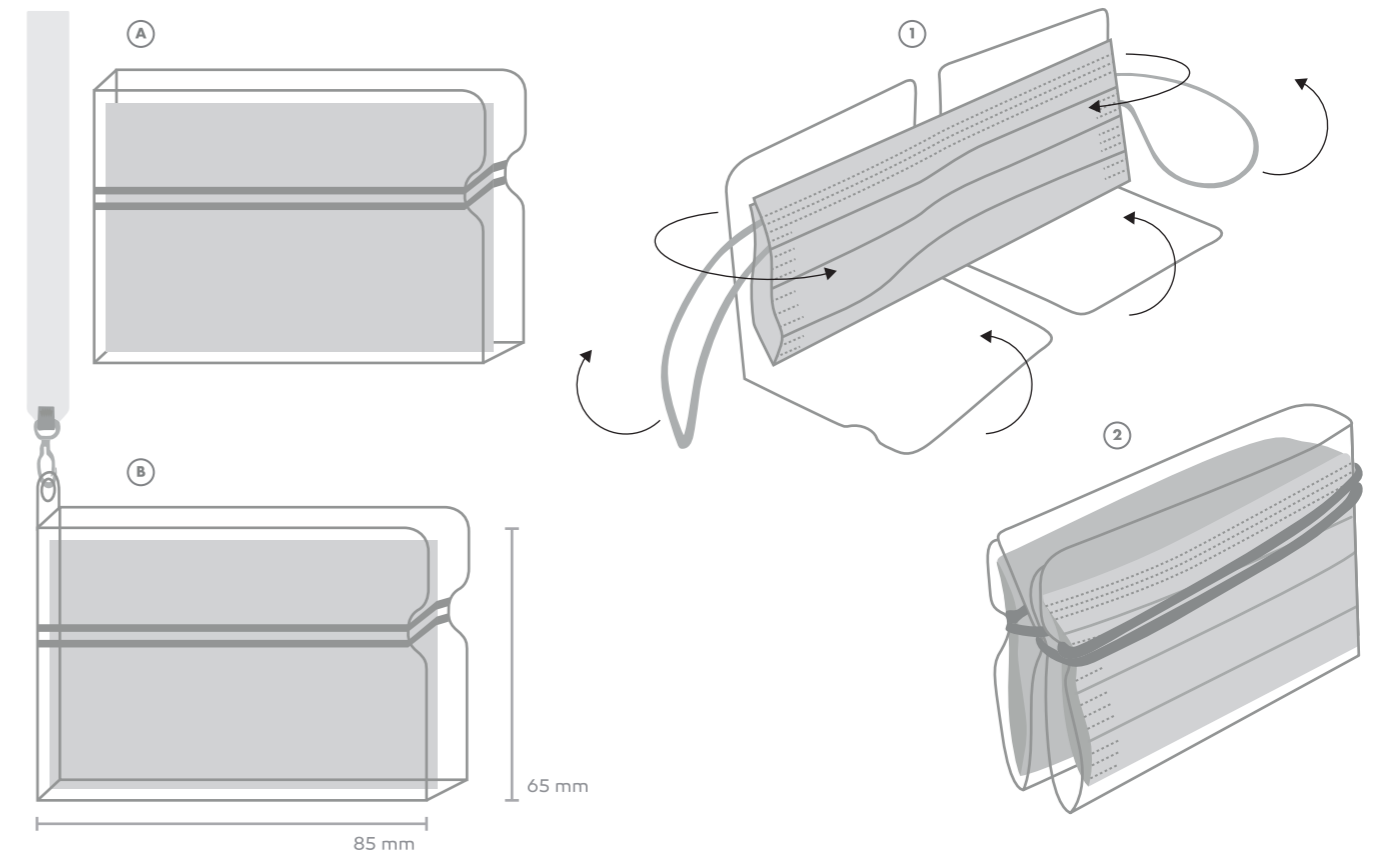



Portamascarillas automontable (PVO14)
 Self-assembly mask holder
 Support de masque auto-montage

Portamascarillas automontable personalizable ideal para el transporte y protección de tu mascarilla, llévalo colgado en el lanyard o guárdalo en el bolsillo, mochila, bolso, etc. Material resistente, automontable, reutilizable y de fácil limpieza.
 Customizable self-assembling mask holder ideal for transporting and protecting your mask, carry it hanging on the lanyard or keep it in your pocket, backpack, bag, etc. Resistant material, self-assembling, reusable and easy to clean.
 Support de masque auto-montage personnalisable idéal pour transporter et protéger votre masque, le porter suspendu à la lanière ou le garder dans votre poche, sac à dos, sac, etc. Matériau résistant, auto-assemblant, réutilisable et facile à nettoyer.



Material. Material. Matériel.
 Polipropileno translúcido o opaco.
 Translucent or opaque polypropylene.
 Polypropylène translucide ou opaque.



Personalización. Personalization. Personnalisation.
 Personalizable a todo color, 1 color o neutro sin impresión.
 Customizable in full color, 1 color or neutral without printing.
 Personnalisable en quadrichromie, 1 couleur ou neutre sans impression.



Área imprimible a todo color
 Full color printable area
 Zone imprimable en couleur

FORMATO / FORMAT / FORMAT

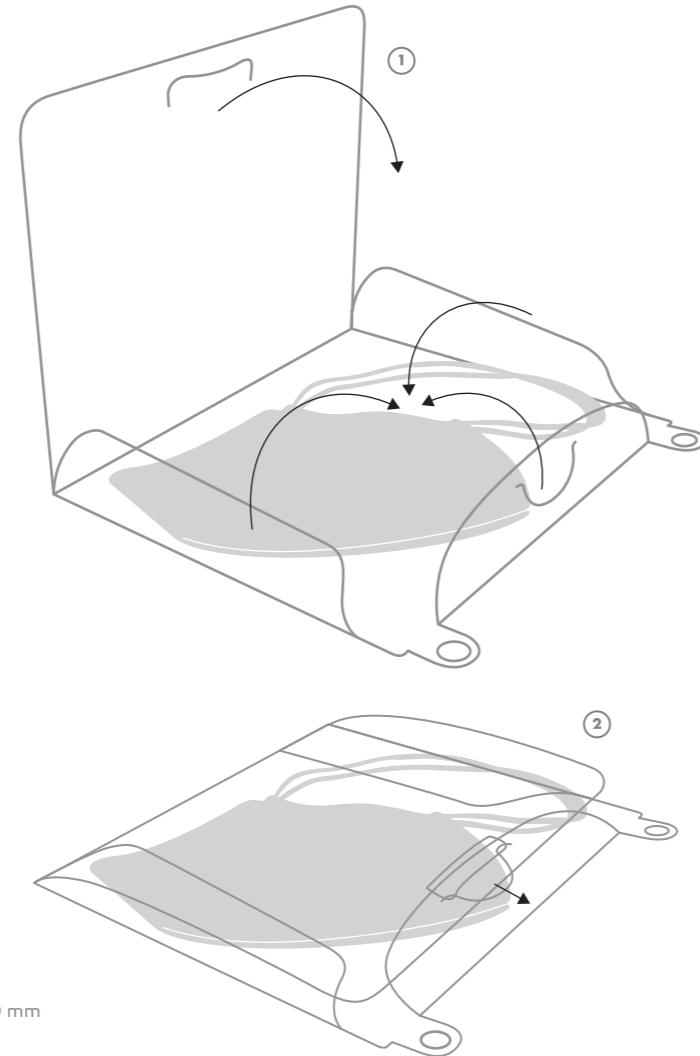
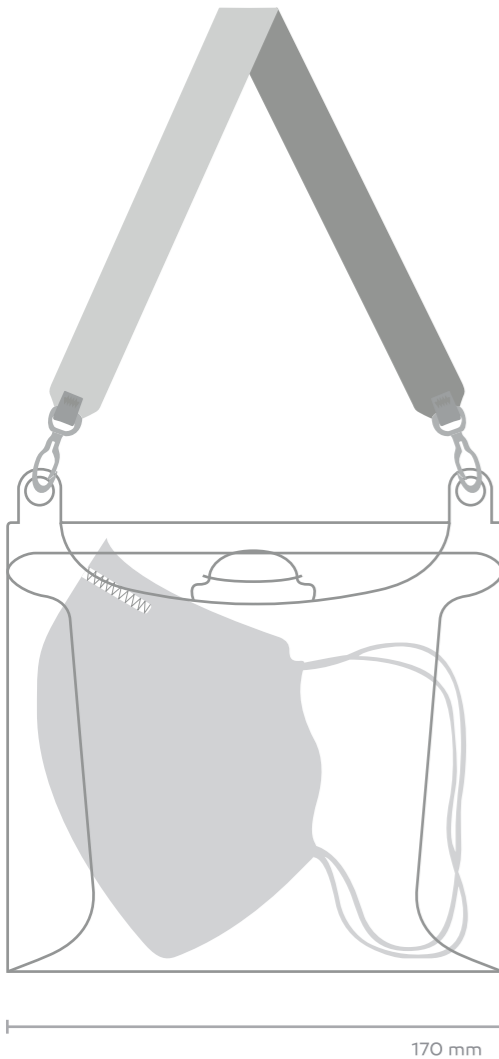

Estuche portamascarillas (PVO15)
 Mask case
 Étui pour masques

Estuche portamascarillas personalizable ideal para el transporte y protección de tu mascarilla, llévalo colgado en el lanyard o guárdalo en el bolsillo, mochila, bolso, etc. Material resistente, reutilizable y de fácil limpieza.
 Customizable mask case ideal for transporting and protecting your mask, carry it hanging on the lanyard or keep it in your pocket, backpack, bag, etc. Resistant material, reusable and easy to clean.
 Étui à masque personnalisable idéal pour transporter et protéger votre masque, utiliser avec lanyard ou le garder dans votre poche, sac à dos, sac, etc. Matériau résistant, réutilisable et facile à nettoyer.



Material. Material. Matériel.
 PP Polipropileno reciclable.
 Recyclable polypropylene PP.
 PP polypropylène recyclable.



Personalización. Personalization. Personnalisation.
 Personalizable a todo color, 1 color o neutro sin impresión.
 Customizable in full color, 1 color or neutral without printing.
 Personnalisable en quadrichromie, 1 couleur ou neutre sans impression.

Colores base estuche.
 Case base colors.
 Couleurs de base étui.

+ Área imprimible a todo color
 + Full color printable area
 + Zone imprimable en couleur



FORMATO / FORMAT / FORMAT

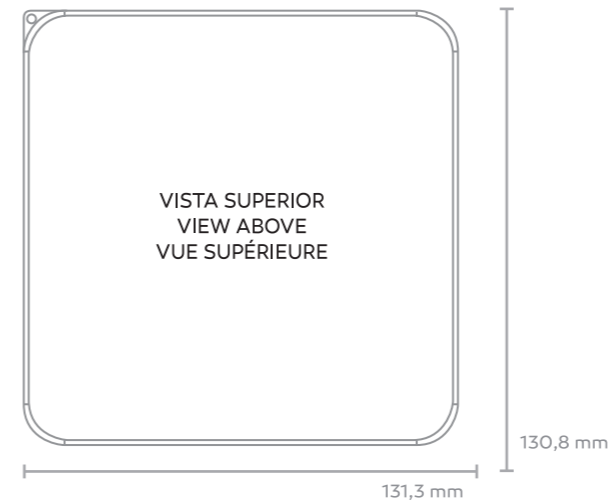



TORRE HIGIÉNICA Y MAMPARAS PROTECCIÓN.

GEL TOWER AND PROTECTION SCREENS. STATION HYGIÈNIQUE ET ÉCRANS DE PROTECTION.



Torre higiénica de desinfección (MCO03) Sanitizer Gel Tower Station hygiénique de désinfection

Columna dispensador de gel desinfectante ideal para cualquier tipo de local o comercio, ubicación libre sin depender de ninguna pared o superficie vertical. Disinfecting gel tower perfect for any type of offices or shops. Free location without depending on any wall or vertical surface. Station hygiénique de désinfection, idéale pour tout type de locaux ou de magasins, emplacement libre sans dépendre d'un mur ou d'une surface verticale.

Material. Material. Matériel.
Estructura de hierro, superficie metálica, panel plástico.
Structure made of iron, metal surface, plastic panel.
Structure en fer, surface métallique, panneau en plastique.

Depósito. Tank. Dépôt.
Cajón con cerradura para garrafas de gel hidroalcohólico 5 lt.
Drawer with lid and lock to place 5-lt. hydroalcoholic gel bottles.
Tiroir avec couvercle et serrure pour placer des carafes hydro-alcooliques de 5 lt.

Personalización. Personalization. Personnalisation.
2 superficies: 1= 297mm x 210mm 2= 195mm x 865mm
2 surfaces: 1= 297mm x 210mm 2= 195mm x 865mm
2 surfaces: 1= 297mm x 210mm 2= 195mm x 865mm

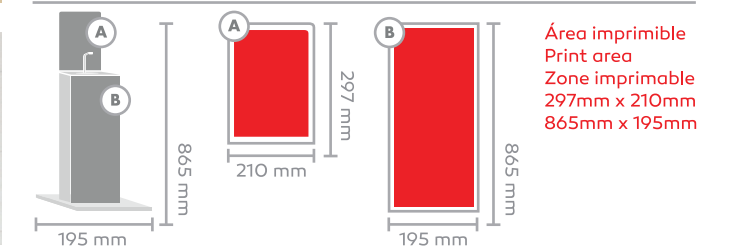

Mamparas de protección (MCO05) Protection Screens Écrans de protection

Evita el contacto directo con agentes biológicos patógenos de transmisión aérea y aumenta la seguridad entre tus clientes y trabajadores de la empresa. Avoid direct contact with pathogenic biological agents and stay safety among your clients and company workers. Évitez tout contact direct avec des agents biologiques pathogènes en suspension dans l'air et augmentez la sécurité de vos clients et des employés de l'entreprise.

Material. Material. Matériel.
Metacrilato 2mm.
Methacrylate 2mm.
Méthacrylate 2mm.

Personalización. Personalization. Personnalisation.
Posibilidad de personalización con el logotipo de empresa.
Possibility of personalization with the logo of the company.
Possibilité de personnalisation avec le logo de l'entreprise.



SOPORTE DE PATAS LATERALES, CLIP VENTOSA	SOPORTE PEANA	SUSPENDIDA CON ANCLAJES
SIDE LEG SUPPORT CLIP WITH SUCTION CUP	SLOTTED SCREWS	SUSPENDED SCREEN HALF-BODY
PIEDS LATÉRAUX ET CLIP AVEC VENTOUSE	AVEC VIS À FENTE	SUSPENDU FORMAT DEMI-CORPS

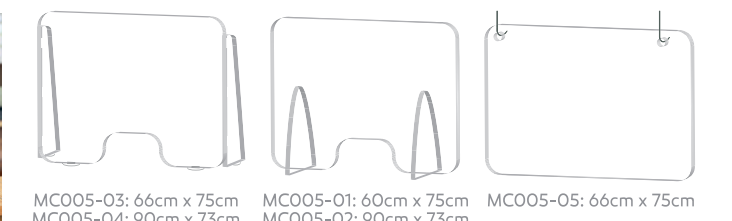
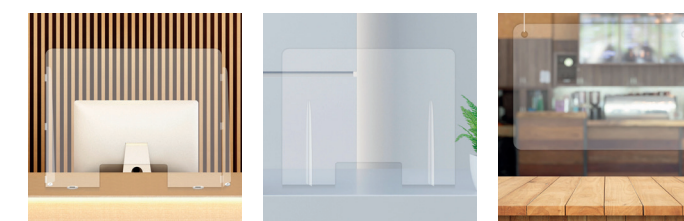

MCO05-03: 66cm x 75cm MCO05-01: 60cm x 75cm MCO05-05: 66cm x 75cm
MCO05-04: 90cm x 73cm MCO05-02: 90cm x 73cm



DISPOSITIVO MULTIFUNCIONAL Y ARENA PLACE.

MULTIFUNCTIONAL DEVICE AND ARENA PLACE. DISPOSITIF MULTIFONCTIONNEL ET ARENA PLACE.



Dispositivo multifuncional McCovid (MCO01) Multifunctional device McCovid Dispositif multifonctionnel McCovid

Dispositivo multifuncional para evitar el contacto directo con diferentes superficies que puedan ser un foco de propagación de enfermedades infecciosas.
Multifunctional device to avoid direct contact with different surfaces that can be a source of spread of infectious diseases.
Dispositif multifonctionnel permettant d'éviter le contact direct avec différentes surfaces pouvant être une source de propagation de maladies infectieuses.

- Material.** Material. Matériel.
Nylon, colores base blanco, negro, azul, verde, rojo, amarillo.
Super resistant Nylon, base colors white, black, blue, green, red, yellow.
Nylon SUPER RESISTANT, couleurs de base blanc, noir, bleu, vert, rouge, jaune.
- Multifunción.** Multifunction. Multifonctions.
Abre puertas, pulsador, moneda de carro, abridor, etc.
Door opener, pushbutton, trolley coin, drink opener, etc.
Ouvre-porte, bouton-poussoir, pièce de monnaie pour chariot, etc.
- Personalización.** Personalization. Personnalisation.
Impresión en toda la superficie (digital) o 1 color (tampografía-serigrafía)
Printing on the entire surface (digital) or 1 color (printing-silk screening)
Impression numérique ou marquage 1 couleur avec tampographie-sérigraphie

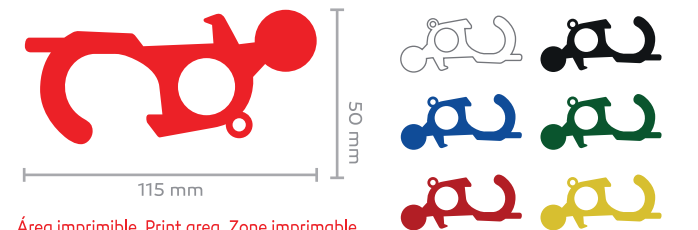

Área imprimible. Print area. Zone imprimable



Delimitador de playa (MCBEACH) Beach delimiter Delimiteur de plage

Delimitador de playa para mantener el distanciamiento social y prevenir posibles contagios, crea parcelas acotadas y espacios seguros entre usuarios.
Beach delimiter to maintain social distance and prevent possible contagion, it creates limited plots and safe spaces between users.
Délimiteur de plage pour maintenir la distance sociale et éviter une éventuelle contagion, il crée des parcelles limitées et des espaces sécurisés entre les utilisateurs.

- Personalización.** Personalization. Personnalisation.
Personalización de la cinta y del color de las piquetas.
Customize the tape and the color of the pegs.
Personnaliser la bande et la couleur des pichets.
- Formatos.** Formats. Formats.
Tamaño L: 4 Piquetas de 30cm, 2 cintas de 8m cada una.
Size L: 4 Sticks 30cm, 2 tapes 8m.
Taille L: 4 piquets de 30 cm, 2 bandes de 8 m.
Tamaño XXL: 4 Piquetas de 30cm, 2 cintas de 16m cada una.
Size XXL: 4 Sticks 30cm, 2 tapes 16m.
Taille XXL: 4 piquets de 30 cm, 2 bandes de 16 m.

